

Southern Intertie

Costs to Date

December 2002

1/6/2003

1

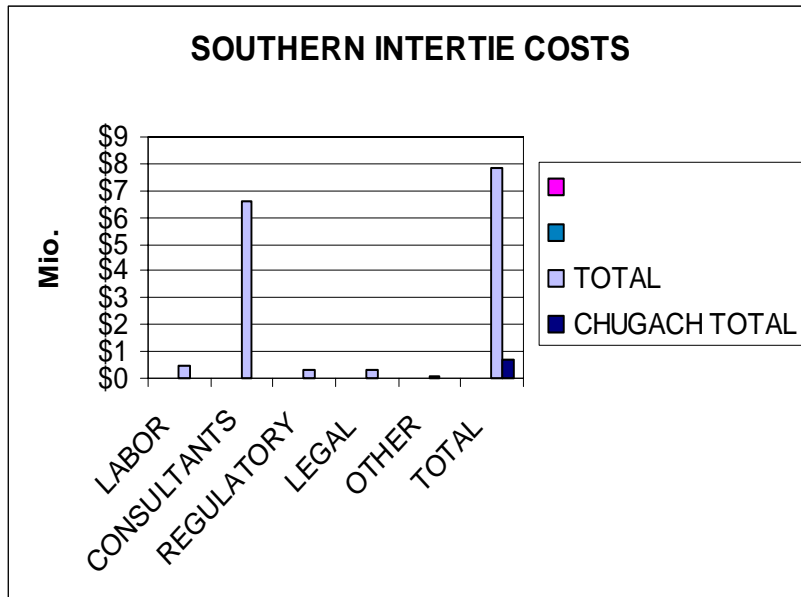

1/6/2003

2

Total Costs

from 1993 to 12/2002

Labor	\$ 496,504
Consultants	\$6,571,804
Regulatory	\$ 348,961
Legal	\$ 319,565
Other	<u>\$ 77,480</u>
Total	\$7,814,314

Chugach Paid \$ 672,917

1/6/2003

3

Chugach Internal Costs

Grant Agreements	\$419,612
Labor Evaluation	\$ 27,671
Economic Evaluation	\$105,738
<u>EIS Process</u>	<u>\$119,896</u>
Total	\$672,917

Chugach Paid \$672,917

1/6/2003

4

CHUGACH ELECTRIC ASSOCIATION







SOUTHERN INTERTIE COSTS

AS OF: 12/1/02

DESCRIPTION	W.O.#	LABOR	CONSULTANTS	REGULATORY	LEGAL	OTHER	TOTAL	NOTES
ROUTE SELECTION TO EIS	E9590081	\$330,673	\$6,440,255	\$348,961	\$67,068	\$38,210	\$7,225,167	work from 1995 to 2002; regulatory costs are reimbursements to federal agencies.
ADMINISTRATIVE COSTS							\$36,126	0.5% per IPG Agreement
TOTAL							\$7,261,293	
REIMBURSED BY GRANT FUNDS							\$6,920,970	
PAID BY CHUGACH							\$119,896	per AIDEA/IPG agreement of 12/2000
PAID BY OTHER IPG							\$220,427	per AIDEA/IPG agreement of 12/2000
CHUGACH INTERNAL								
SOUTHERN INTERTIE	L9400625	\$90,887			\$10,390	\$1,659	\$102,936	IPG Agreement preparation
SOUTH. INTERTIE - LABOR EVALUATION	E9500636	\$1,697	\$25,811			\$163	\$27,671	Chugach BOD requested study
1993 EFFORT SOUTH.INTERTIE	L9300611	\$73,247			\$242,107	\$1,323	\$316,676	Grant related Agreements
DFI 1997/98			\$105,738				\$105,738	Chugach BOD requested study
TOTAL CHUGACH TOTAL		\$496,504	\$6,571,804	\$348,961	\$319,565	\$41,354	\$7,814,314	
							\$672,917	

**ALTERNATIVES STUDIED
IN DETAIL
SOUTHERN INTERTIE PROJECT
FIGURE S-1**

Legend

-  Applicant's Proposed Route
-  Enstar Route Options
-  Tesoro Route Options
-  Chugach State Park
-  Kenai National Wildlife Refuge
-  Chugach National Forest
-  Private, Borough, or State Selected Lands

Note: No-action alternative is shown in inset in upper left-hand corner of map.

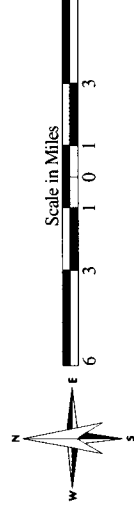

Base Map Sources:
Municipality of Anchorage (1994),
Chugach National Forest (1995),
Kenai Peninsula Borough (1994),
USGS 1:63,360 and 1:25,000 Quads,
Contour Interval: 200 Feet
Contour Labeling in Feet

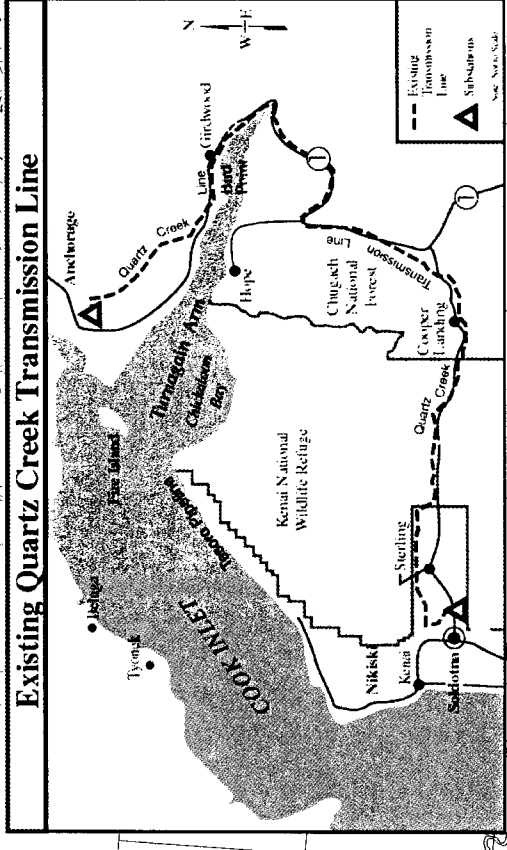
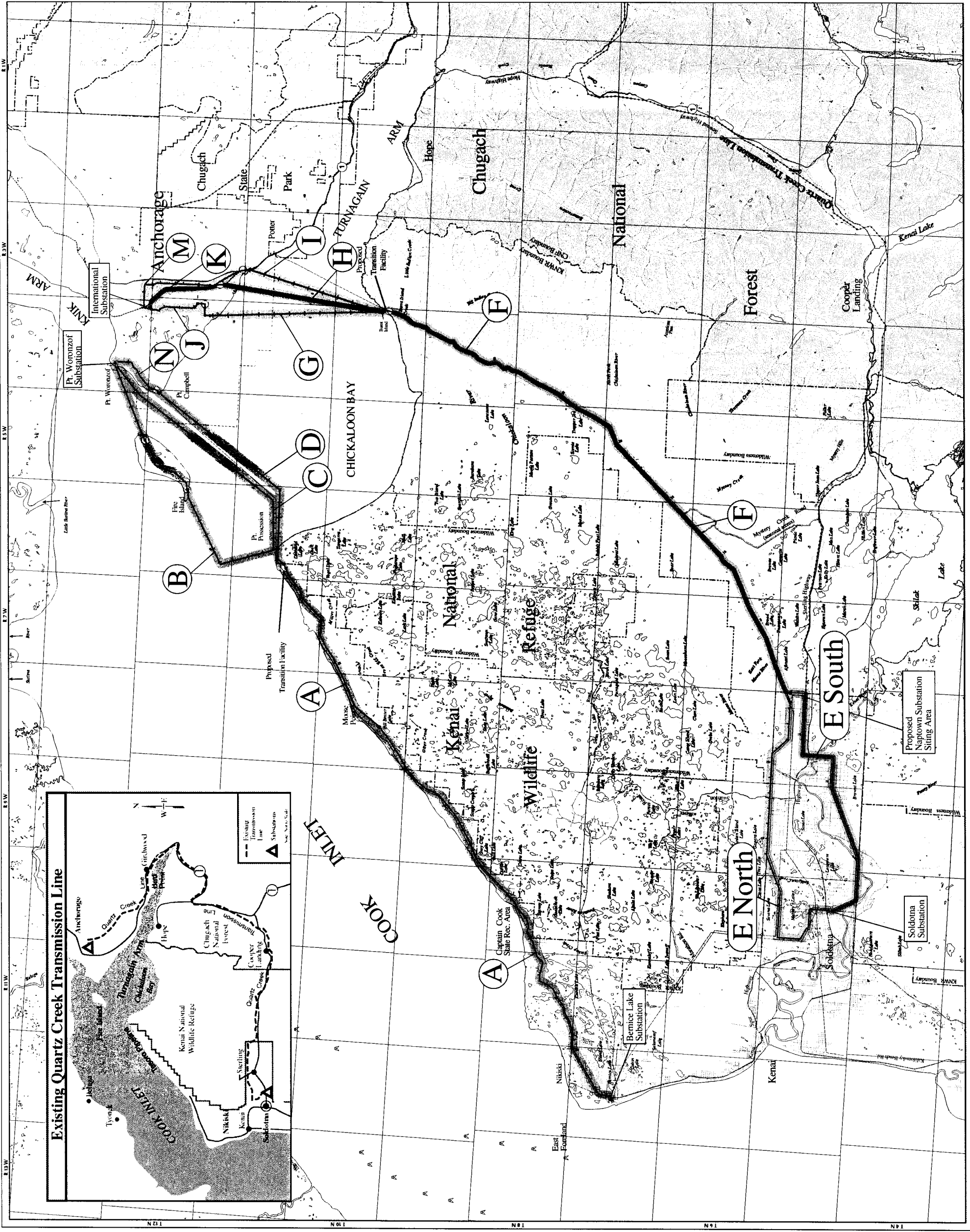

TESORO ROUTE COMPONENTS

DESCRIPTION	1998 ESTIMATE (MILLIONS)	
OVERHEAD LINES	\$22.6	COSTS INCLUDE:
UNDERGROUND CABLES	\$13.4	I. For OH Lines and Stations
SUBMARINE CABLES	\$41.3	Design 6.50%
TRANSITION STATIONS	\$2.2	Const.Mgt. 7.00%
SUBSTATIONS AND REACTIVE COMPENSATION	\$14.7	Contingency 10.00%
RIGHT OF WAY	\$1.1	II. For Submarine
PRECONSTRUCTION SURVEYS	\$1.2	Design 3.00%
		Constr. Mmgt. 3.50%
		Contingency 10.00%
<hr/>		
SUB TOTAL	\$96.5	
		12/2002 ACTUALS
ENVIRONMENTAL COSTS	\$7.3	
GRANT FUNDS (09/02)	-\$67.2	
IPG FUNDING REQUIRED	\$29.3	

TESORO ROUTE

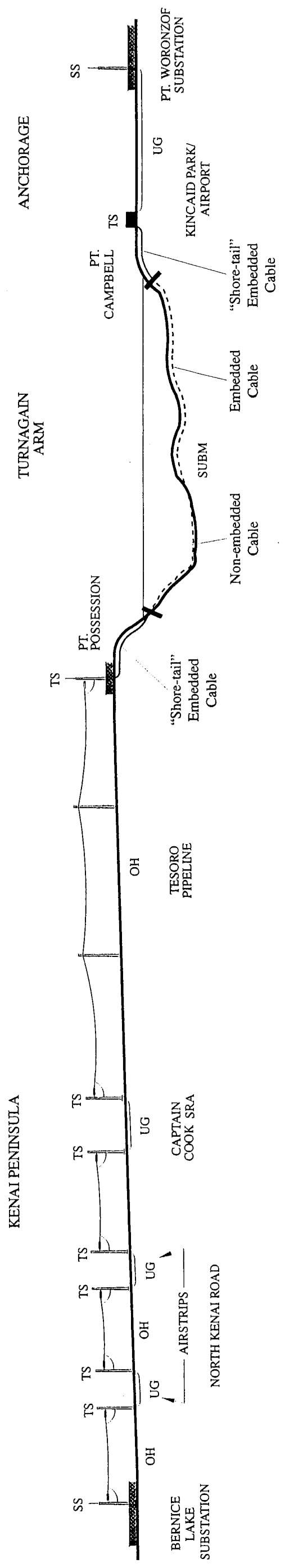

- LEGEND-FACILITY TYPES**
- OH - OVERHEAD LINE
 - UG - UNDERGROUND LINE
 - SUBM - SUBMARINE CABLE
 - TS - TRANSITION STATION
 - SS - SUBSTATION

REPRESENTATIVE ROUTE PROFILE
 SOUTHERN INTERTIE PROJECT
 FIGURE 2-10
 DE/S 2001

NOT TO SCALE

Chugach Electric Association
Southern Intertie Project

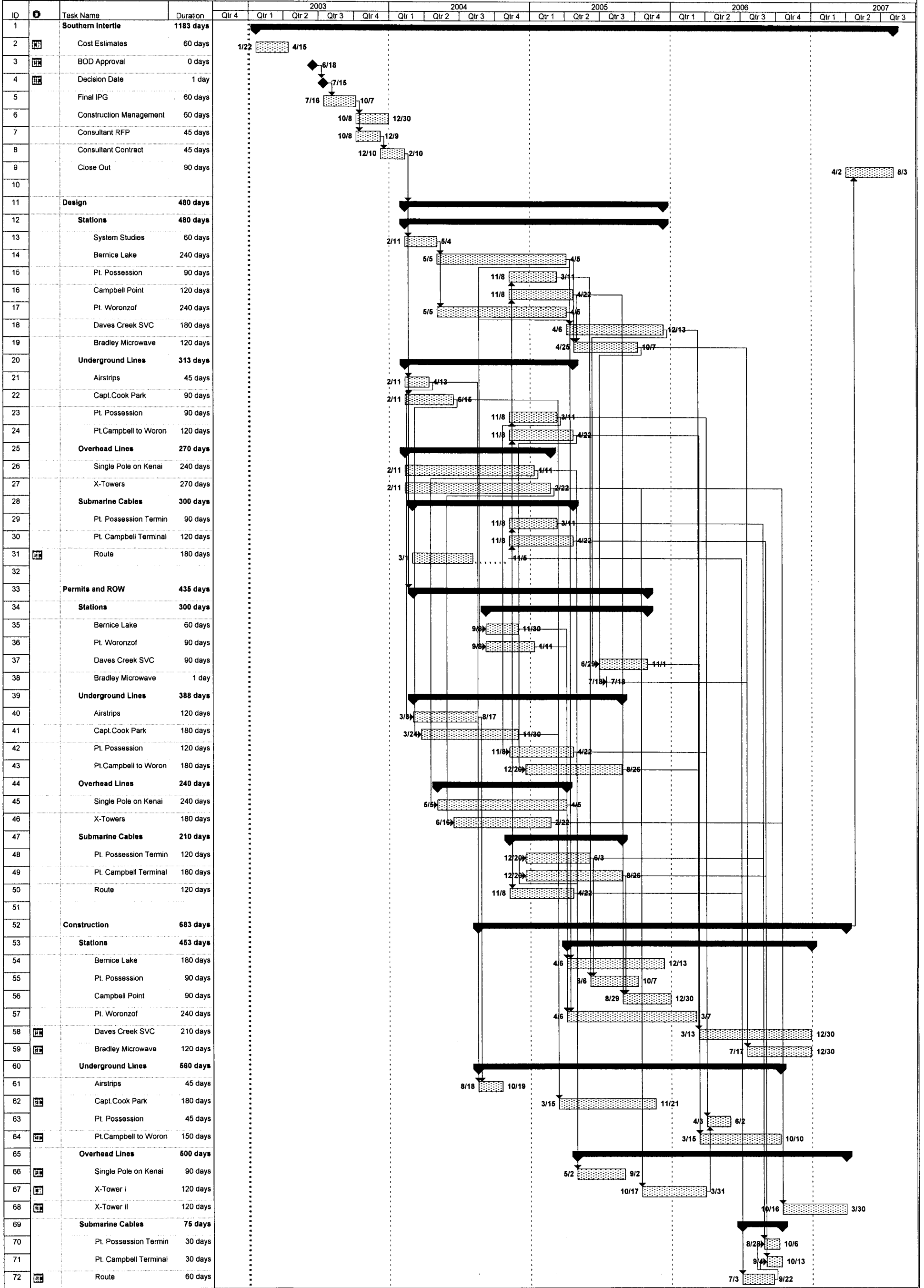

ID	Task Name	Duration	2003 Qtr 4	2003 Qtr 1	2003 Qtr 2	2003 Qtr 3	2003 Qtr 4	2004 Qtr 1	2004 Qtr 2	2004 Qtr 3	2004 Qtr 4	2005 Qtr 1	2005 Qtr 2	2005 Qtr 3	2005 Qtr 4	2006 Qtr 1	2006 Qtr 2	2006 Qtr 3	2006 Qtr 4	2007 Qtr 1	2007 Qtr 2	2007 Qtr 3	
1	Southern Intertie	1183 days	[Summary Bar]																				
2	Cost Estimates	60 days	1/22	[Task Bar]																			
3	BOD Approval	0 days	[Task Bar]																				
4	Decision Date	1 day	[Task Bar]																				
5	Final IPG	60 days	[Task Bar]																				
6	Construction Management	60 days	[Task Bar]																				
7	Consultant RFP	45 days	[Task Bar]																				
8	Consultant Contract	45 days	[Task Bar]																				
9	Close Out	90 days	[Task Bar]																				
10			[Task Bar]																				
11	Design	480 days	[Summary Bar]																				
12	Stations	480 days	[Summary Bar]																				
13	System Studies	60 days	[Task Bar]																				
14	Bernice Lake	240 days	[Task Bar]																				
15	Pt. Possession	90 days	[Task Bar]																				
16	Campbell Point	120 days	[Task Bar]																				
17	Pt. Woronzof	240 days	[Task Bar]																				
18	Daves Creek SVC	180 days	[Task Bar]																				
19	Bradley Microwave	120 days	[Task Bar]																				
20	Underground Lines	313 days	[Summary Bar]																				
21	Airstrips	45 days	[Task Bar]																				
22	Capt. Cook Park	90 days	[Task Bar]																				
23	Pt. Possession	90 days	[Task Bar]																				
24	Pt. Campbell to Woron	120 days	[Task Bar]																				
25	Overhead Lines	270 days	[Summary Bar]																				
26	Single Pole on Kenai	240 days	[Task Bar]																				
27	X-Towers	270 days	[Task Bar]																				
28	Submarine Cables	300 days	[Summary Bar]																				
29	Pt. Possession Termin	90 days	[Task Bar]																				
30	Pt. Campbell Terminal	120 days	[Task Bar]																				
31	Route	180 days	[Task Bar]																				
32			[Task Bar]																				
33	Permits and ROW	435 days	[Summary Bar]																				
34	Stations	300 days	[Summary Bar]																				
35	Bernice Lake	60 days	[Task Bar]																				
36	Pt. Woronzof	90 days	[Task Bar]																				
37	Daves Creek SVC	90 days	[Task Bar]																				
38	Bradley Microwave	1 day	[Task Bar]																				
39	Underground Lines	388 days	[Summary Bar]																				
40	Airstrips	120 days	[Task Bar]																				
41	Capt. Cook Park	180 days	[Task Bar]																				
42	Pt. Possession	120 days	[Task Bar]																				
43	Pt. Campbell to Woron	180 days	[Task Bar]																				
44	Overhead Lines	240 days	[Summary Bar]																				
45	Single Pole on Kenai	240 days	[Task Bar]																				
46	X-Towers	180 days	[Task Bar]																				
47	Submarine Cables	210 days	[Summary Bar]																				
48	PL Possession Termin	120 days	[Task Bar]																				
49	Pt. Campbell Terminal	180 days	[Task Bar]																				
50	Route	120 days	[Task Bar]																				
51			[Task Bar]																				
52	Construction	683 days	[Summary Bar]																				
53	Stations	453 days	[Summary Bar]																				
54	Bernice Lake	180 days	[Task Bar]																				
55	Pt. Possession	90 days	[Task Bar]																				
56	Campbell Point	90 days	[Task Bar]																				
57	Pt. Woronzof	240 days	[Task Bar]																				
58	Daves Creek SVC	210 days	[Task Bar]																				
59	Bradley Microwave	120 days	[Task Bar]																				
60	Underground Lines	560 days	[Summary Bar]																				
61	Airstrips	45 days	[Task Bar]																				
62	Capt. Cook Park	180 days	[Task Bar]																				
63	Pt. Possession	45 days	[Task Bar]																				
64	Pt. Campbell to Woron	150 days	[Task Bar]																				
65	Overhead Lines	500 days	[Summary Bar]																				
66	Single Pole on Kenai	90 days	[Task Bar]																				
67	X-Tower I	120 days	[Task Bar]																				
68	X-Tower II	120 days	[Task Bar]																				
69	Submarine Cables	75 days	[Summary Bar]																				
70	Pt. Possession Termin	30 days	[Task Bar]																				
71	Pt. Campbell Terminal	30 days	[Task Bar]																				
72	Route	60 days	[Task Bar]																				

Project: Southern Intertie Design and C Date: Fri 1/3/03	Task	[Dotted Box]	Milestone	[Diamond]	Rolled Up Critical Task	[Thick Dotted Box]	Split
	Critical Task	[Thick Dotted Box]	Summary	[Thick Diamond]	Rolled Up Milestone	[Diamond]	External Tasks
	Progress	[Solid Bar]	Rolled Up Task	[Thick Solid Bar]	Rolled Up Progress	[Thick Solid Bar]	Project Summary