

CHUGACH ELECTRIC ASSOCIATION, INC.

ELECTRICAL FACILITY CLEARANCE REQUIREMENTS FOR CONSTRUCTION OR MAINTENANCE NEAR ELECTRICAL FACILITIES

Chugach's concern for the safety of non-qualified personnel working adjacent to its electrical facilities, its concern for the public in general, and its requirement that only qualified personnel under the employ of qualified electrical contractors handle electrical facilities such as cable, poles, switch cabinets, etc., is based upon the following considerations:

- The potential for serious injury and resulting liability is extremely high when dealing with voltages as high as 230,000 volts on overhead and underground lines.
- Certain types of equipment, particularly cable, can easily be damaged by improper handling. For example, when cable is hit or improperly suspended (common during excavation adjacent to cables), the scraped, cut, or over-stressed insulation will almost always result in premature failure of the cable. The highest risk to personnel is a failure while the cable is being handled during excavation or construction. Undetected construction damage may result in a subsequent cable failure with consumer outages for periods of up to 48 hours during winter conditions.
- The stability of overhead pole lines or padmounted equipment is jeopardized with improper excavation and backfill. This may expose the public, as well as maintenance or construction personnel, to high voltages and create consumer power outages.

The above concerns can be minimized or eliminated by the use of properly trained, licensed, and certified electrical outside linework personnel. The National Electrical Safety Code (NESC), the United States Occupational Safety and Health Administration (OSHA) and the Alaska State OSHA support this position as well as the clearances addressed herein.

NESC, Section 2, *Definitions of Special Terms* defines "qualified" as "Having adequate knowledge of the installation, construction or operation of apparatus and the hazards involved." Only qualified persons are permitted to handle or work on or adjacent to energized electrical facilities. This includes not only pole lines but also padmounted and underground facilities. Within the NESC, two rules specifically address the need for qualified persons to perform work on or about energized facilities:

Rule 420B1 states, *"Employees whose duties require working on or in the vicinity of energized equipment or lines shall perform only those tasks for which*

they are trained, equipped, authorized, and so directed. Inexperienced employees shall: (a) work under the direction of an experienced and qualified person at the site; and (b) perform only directed tasks."

Rule 420B3 states, *"Employees who do not normally work on or in the vicinity of electric supply lines and equipment but whose work brings them into these areas for certain tasks shall proceed with this work only when authorized by a qualified person."*

29CFR1910.269 contains the training and documentation requirements for a qualified person.

29CFR1926.550 (a) (15) addresses crane operations near electrical lines. For lines rated over 50 kilovolts (kV), minimum clearance between the lines and any part of the crane or load must be 10 feet plus 0.4 inch for each 1 kV over 50 kV -- or twice the length of the line insulator, but never less than 10 feet.

CHUGACH SYSTEM VOLTAGES	
Normal Voltage (Phase-to-Phase)	Minimum Clearance Required
Operations Near High-Voltage Overhead Power Lines to 50 kV	10 Feet
Over 50 kV to 200 kV	15 Feet
Over 200 kV to 350 kV	20 Feet

Specifically, 29CFR1926 (a) (15) (iv) requires a "Safety Observer" during crane operations if the equipment is operating where it is difficult for the operator to maintain the desired clearance by visual means of an overhead power line. Alaska Statutes, Sections 18.60.670 through Section 18.60.695 govern placement and operation of equipment near overhead electrical lines or conductors. 29CFR1926, Subpart P addresses the specific requirements involved with trenching operations. These include prior notice to utility companies, prior location of utility facilities, and proper supports once the facilities are uncovered. Furthermore 29CFR Sections 1910.180; 1910.333; 1926.416; 1926.550; and 1926.651 regulate activities relative to job site electrical facilities.

Again, Chugach's concern for the safety of all personnel affected by work adjacent to its energized facilities has led to the development of the attached policy.

ELECTRICAL FACILITY CLEARANCE REQUIREMENTS

The following requirements have been developed to help provide a safer work site to those personnel working adjacent to Chugach's electrical facilities and to protect Chugach facilities that are located in the area of work being done by State or Municipal entities and private construction and maintenance projects.

A. NOTIFICATION

It is recommended that Chugach be informed of construction/maintenance activities as early as possible in the design process and be included in timely plan reviews. Any work that needs to be performed on Chugach facilities must have prior Chugach approval.

1. Overhead Facilities

Any work in the proximity of overhead power lines shall be preceded by a call to Chugach at 762-7659 or 762-7669, 48 hours in advance, to notify the Line Construction and Maintenance Department of the planned work and be in compliance with 29CFR1926 (a) (15), and A.S. 18.60.670. If equipment, tools, machinery, or material must work in proximity closer than the minimum clearances outlined in 29CFR1926 (a) (15), and A.S. 18.60.670, the requirements of A.S. 18.60.680 shall be complied with before work can proceed.

All necessary arrangements to be made with Chugach by the requesting party for compliance with A.S. 18.60.680 shall be arranged in advance of the project start date.

2. Underground Facilities

Alaska Statutes, 42.30.400 through 42.30.490, Anchorage Municipal Code, 24.40 and 26.90, and 29CFR1926, Subpart P place requirements on contractors who will be excavating around or adjacent to underground utilities. Advance notification requirements, underground facility locates, and the responsibilities for protection of utility facilities by contractors are specified in these regulations. All requests for locates of Chugach underground facilities are to be made through the "Locate Call Center" at 278-3121. In addition, prior to excavating, Chugach shall be contacted 48 hours in advance at 762-7659 or 762-7669.

Locate surface markings are only reasonably accurate to +/- two (2) feet. As a general rule, Chugach requires hand-digging within two (2) feet of locate marks but in some cases may require three (3) or four (4) feet, depending on the actual facility involved and field conditions at the project site. Maintaining locate marks is the responsibility of the party requesting the locate. Chugach may charge for re-locating and re-marking facilities that were previously marked.

B. UNDERGROUND CABLE EXCAVATION

1. Any excavation which is within a three (3) foot radius of a cable and parallels a cable for a distance greater than twenty (20) feet in length (see Section H-1 below) may require relocation of that cable. Excavations shorter in length and/or closer may also require relocation. At a minimum, cables that will require exposure must be exposed by hand-digging only, and by a qualified person under the employ of a qualified electrical contractor. See Drawing No. F-062388 attached.
2. Any excavation, such as a trench which crosses cable(s), shall be limited to twenty (20) feet in width and have provisions for the exposed cable to be supported every two (2) feet on a cross beam in such a manner that the outer cable cover shall not be damaged in any way. The cable support work and excavation within the three (3) foot radius (see Section H-1) shall be done by a qualified person under the employ of a qualified electrical contractor.

NOTE: When excavation must occur within the limits specified in B.1, and B.2, above, reasonable efforts will be made by Chugach to de-energize the direct buried cable if system conditions and personnel requirements allow. Even if the cable has been de-energized, a "Cable Watch" by a qualified person under the employ of a qualified contractor is still required. To request the de-energization of the cable, contact Chugach at 762-7659 or 762-7669 during business hours. Requests must be made three (3) working days in advance of the outage date requested. After hours, contact Chugach's Power Control Center at 762-4660.

Under no circumstances will Chugach allow any of its underground cable(s) to remain energized after it has been exposed, unless it is protected by supplementary mechanical protection approved by Chugach or unless a qualified person is on site at all times.

3. Should any cable be exposed by non-qualified personnel, Chugach must be immediately contacted for field investigation before work may resume in the immediate area of such exposed cable.

Chugach recognizes that reasonable continuation of work may be required around energized underground cables after Chugach inspects the site. When this occurs, it is the responsibility of the construction contractor working at the site to arrange for qualified personnel as well as payment of the costs of said personnel and/or equipment. Chugach will neither arrange for, nor provide qualified personnel to satisfy this requirement unless it determines it is in its best interest on a case-by-case basis. Where Chugach is otherwise forced to subsequently take steps to ensure the safety of the site, it will advise the construction contractor that it will pass these costs to the construction contractor.

4. In all cases, a final minimum burial depth of 40 to 60 inches (depending on the operating voltage) for primary cable and 30 inches for secondary cable shall be

maintained. If, however, existing Federal, State, or Municipal permit conditions require depths in excess of the 40 inches, then the cable shall be buried at the depth required in the permit. The depth is measured from the top of the conductor(s) to final grade at the shallowest depth. Burial shall be in compliance with Chugach Std. SUR2-3 through 6 (supplied upon request).

5. Projects which increase the final grade over Chugach facilities that are not intended to be placed deeper shall require relocation of those facilities if the depth of burial of the cables exceeds 60" from final grade of the project.
6. In addition to the foregoing, excavations near transmission underground cables will require the following:
 - a) Excavation Parallel to Transmission Voltage Level Power Lines: Chugach will require its Locate Contractor to notify excavators when a locate request includes the locating of cables that exceed 25kV Distribution Voltages.

When excavation is planned that will come within close proximity (ten (10) feet), expose, parallel or undermine sections of Chugach's Transmission Underground Cables, special precaution and safety consideration must be taken. These cables operate at voltages in excess of 34,000 volts and up to 230,000 volts phase-to-phase. These cables provide power to tens of thousands of Chugach customers and require extraordinary protection. The following guidelines shall apply:

Chugach Operations Department shall be contacted at (907) 762-7655 in advance of the planned excavation at least three (3) business days prior to beginning excavation. Chugach requires that a qualified person (see Sec. H-7 for definition of a qualified person) be on site at all times during excavation activity that comes within ten (10) feet of any transmission cable. The contractor shall arrange and pay for a qualified person from Chugach or, with approval, from one of Chugach's approved and qualified contractors (see Section H-6 for definition of a qualified contractor). Excavations closer than ten (10) feet shall require exposure of the cables at the intersecting point or at intervals of not less than every twenty-five (25) feet for parallel excavations by qualified personnel to determine the exact location of the cable prior to machine excavation as allowed by law.

Because of the high voltage, excavations within ten (10) feet of a transmission cable can expose unqualified workers to extremely unsafe conditions. Prior planning by the excavator with coordination through Chugach and Chugach approval of construction activity within ten (10) feet of transmission cable is required.

Chugach shall approve, in advance, any plan for directional drilling, boring, pile driving or other type of "trenchless" construction in the vicinity of its transmission cables prior to any construction activity.

Chugach may require a special locate utilizing Ground Penetrating Radar to locate critical facilities.

C. STRUCTURE EXCAVATION

1. Equipment Pads or Vaults

Temporary excavation is allowed with a maximum slope of 1:1 beginning three (3) feet from the exterior edge of a concrete pad or vault. The final grade shall consist of a level area radiating out a minimum of four (4) feet, measured from the exterior edge of the pad or vault, and a maximum slope of 2:1 beginning from that four (4) foot distance from the exterior edge of the pad or vault. For both temporary and final grade situations, a level area extending ten (10) feet out from the edge of the concrete pad in front of equipment doors or access panels is necessary. Refer to Drawing No. F-062388 attached.

If the slope cannot be maintained at the grades specified above, additional protection such as barriers or piling is required. All shoring and excavation (closer than the above limits) shall be done by a qualified person(s) under the employ of a qualified electrical contractor.

2. Concrete-Encased Duct

Excavation under a concrete-encased duct requires a method designed and certified by an Alaska-registered civil engineer and approved by Chugach. Installation of the temporary shoring or bracing shall be done under the supervision of a qualified person under the employ of a qualified electrical contractor.

D. POLE/GUY ANCHOR EXCAVATION

Excavation beginning no closer than a three (3) foot radius from a pole or guy anchor in stable soil conditions or a ten (10) foot radius from a pole or guy anchor in organic/unstable soil conditions is allowed, provided the slope from that point does not exceed 1:1. Refer to Drawing No. F-062388 attached.

Excavation closer than the limits defined above or within the above guidelines for more than one consecutive pole requires shoring of each pole. Pole shoring shall conform to Chugach specifications XP-X/Y (steel pile shoring) or XM40/XM40A (wood pole shoring) as approved by Chugach for the specific excavation. Specifications will be supplied upon request. All work for installing the piles must be performed within the OSHA guidelines. Shoring by other methods requires prior approval by Chugach on a case-by-case basis.

Any excavation that may expose the pole butt requires a structural analysis of the pole shoring method. The analysis shall be performed by an Alaska-licensed

professional engineer familiar with electrical transmission and distribution design standards in use by Chugach.

All shoring and excavation (closer than the above limits) shall be done by a qualified person under the employ of a qualified electrical contractor.

E. RELOCATION REQUIRED

Where protection of the cable and structures cannot be maintained, as required in Sections A, B, and C, relocation of those facilities will be required prior to the intended work and at the contracting agency's expense.

F. BACKFILL

Replacement backfill for electrical facilities must be in accordance with Chugach specifications and done by a qualified person under the employ of a qualified electrical contractor.

A damaged underground facility may not be reburied until it is repaired or re-ed to the satisfaction of Chugach.

G. INSPECTION AND APPROVAL

All work on or in the immediate vicinity of Chugach facilities, such as backfilling, temporary support, shoring, and relocations are subject to prior approval and inspection by Chugach. On large projects where inspection time is substantial, all costs for inspection shall be the responsibility of the agency or entity contracting for the work. Reimbursement to Chugach shall be in accordance with Chugach's tariff, Section 8.

Any questions or approvals involving these requirements should be addressed to the attention of the Chugach Line Operations and Maintenance Manager at 762-7659.

H. MISCELLANEOUS

1. Depending on the soil type, depth and length of the excavation, type of Chugach facility involved, and the certainty of the cable locate, excavations can be approved within a two (2) foot radius of cable on a case-by-case basis.
2. Stable soil conditions are defined as all dry and non-organic. Soil conditions shall be evaluated and approved on a case-by-case basis by Chugach. The evaluation will be done using 29CFR1926, Subpart P, "*Excavations*" as a guide.
3. Excavation, except as noted, shall be defined as mechanically done by a backhoe, scraper, grader, auger, or other piece of equipment.

4. Cables are defined as insulated cable whether buried directly or in conduit. The guidelines for cables also include 600-Volt pedestals and other small electrical apparatus associated with cable but not included under pads or vaults.
5. Spare conduit is not included in these provisions except to the extent of providing temporary support when exposed and inspected by Chugach prior to the placement of proper backfill.
6. Chugach defines a *qualified electrical contractor* as a contractor registered in the State of Alaska who has an Electrical Administrator's License in the Outside Linework category; or who has an employee with an Electrical Administrator's License in the same category registered with the contractor.
7. Chugach defines a *qualified person* as a journeyman lineman who holds a current Certificate of Fitness in the Journeyman Lineman category issued by the State of Alaska.
8. Chugach defines *hand-digging* as the removal of soil with hand tools or with an air-knife tool (compressed air jet).

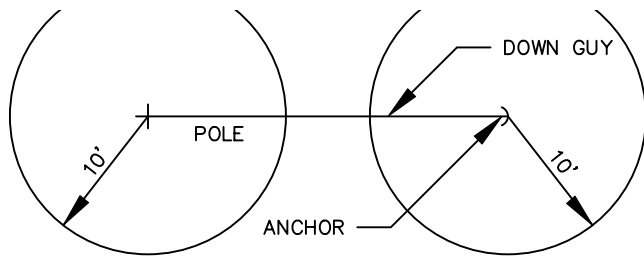

PLAN

(RADIUS OF UNDISTURBED SOIL)

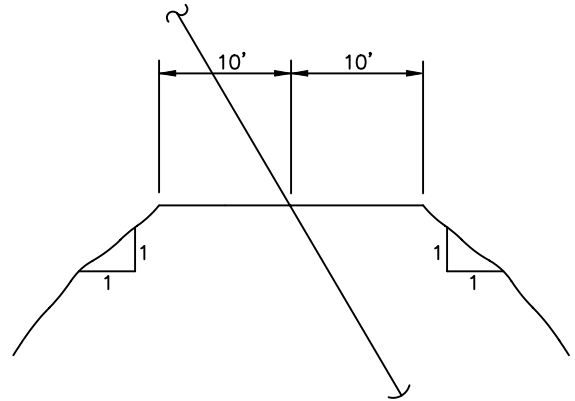
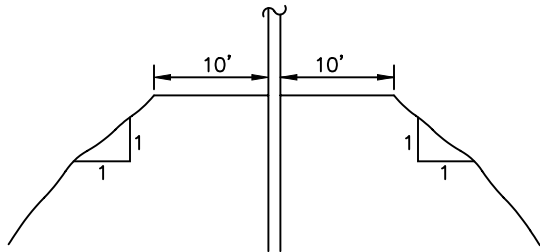

PROFILE

POLES/GUYS

NOTE:
FOR VERY UNSTABLE SOIL CONTACT CHUGACH ELECTRIC.

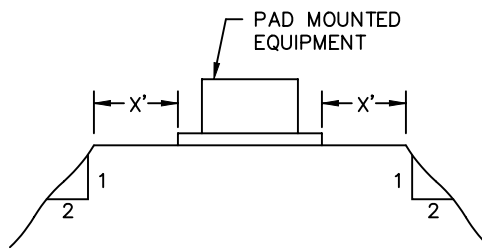
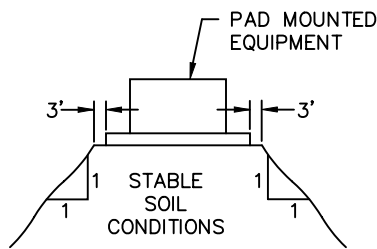

X': 10' ON DOOR/ACCESS SIDES. 4' ON OTHER SIDES.

DURING CONSTRUCTION
SUPPLEMENTAL SUPPORT REQUIRED FOR EXCAVATIONS WITHIN 5' OF PADMOUNTED EQUIPMENT LOCATED ON UNSTABLE SOIL CONTACT CHUGACH ELECTRIC

AFTER CONSTRUCTION

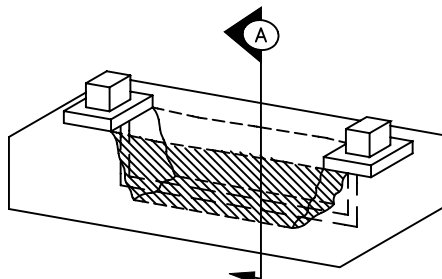

PARALLEL EXCAVATION

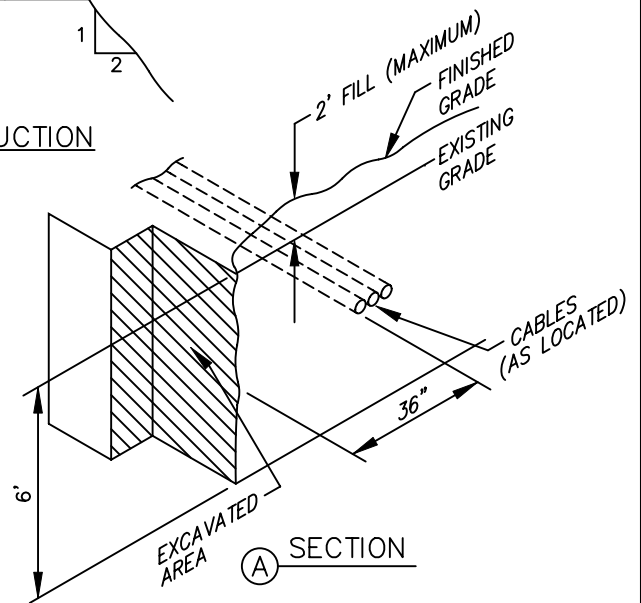

STRUCTURES/CABLES

REV. NO.: 3 DATE: 1/28/98
 Standards Engineer: _____
 Mgr., Dist. Engineering: _____
 Mgr., Const. & Maint.: _____
 Dir., T&D Services Div.: _____



EXCAVATION LIMITS
DEFINITION OF LIMITS REQUIRING
NO ADDITIONAL STRUCTURAL SUPPORT

DRAWING NUMBER F-062388 SHEET 1 OF 1